

borg &
overström



Distinctive
by design.

u2

borg &
overström

High-performance hydration

Practical, reliable and visually striking, this innovative tap brings a high capacity refreshment solution to any commercial or Horeca environment.

Reasons to choose

- High capacity output
- Low energy consumption
- Compact under-counter unit
- Robust, solid build quality
- Simple to operate and maintain
- Simple-fit ventilation base included with S2

T: 01223 833661 www.simplygreatcoffee.co.uk



Simply, great
coffee
u2

Distinctive
by design.

u2

borg &
overström



Water system



Direct Chill

Configuration



Undercounter

Water options



Chilled



Ambient



Sparkling



Distinctive
by design.



Catering for capacity

The U2 boasts a compact yet high capacity under-counter appliance. It delivers a speedy throughput of 80 litres per hour at a consistent chilled temperature, making it the perfect solution for busy environments including Horeca applications.

Borg & Overström Totality®



Driven by a relentless pursuit of excellence, Borg & Overström Totality® is a research and development methodology for the advancement of hygiene, innovation and technology in refreshment systems.



Ultra-violet sterilising system
For added hygiene confidence, appliances can be fitted with Viovand™ – an ultra-violet sterilisation process that reduces water-borne bacteria.



Laboratory certified 99.999% bacteria-reduced
Every Borg & Overström appliance undergoes an anti-microbial, antipathogen, sanitising procedure. The reassurance of hygienically safe appliances is provided by the unique bacteria-reducing process, Sterizen™.



World-class filtration
For the ultimate drinking experience, Borg & Overström appliances can be pre-fitted with a 3M filter to reduce sediment, chlorine, odours and scale.

Distinctive
by design.



U2 models	Undercounter - S2 W330xD370xH362mm	Water system	Dispense height	Max power consumption	Stainless Steel	Tap style
Power requirements Hertz 50/Volts 230	Chilled & Ambient	Dry Chill®	286mm	570W	601511	Twin Head W150xD240xH470mm
Chilled temperature Min 2°C/Max 10°C	Chilled & Sparkling	Dry Chill®	286mm	570W	601512	Twin Head W150xD240xH470mm
Throughput litres per hour S2 Chilled & Sparkling 80	Chilled, Ambient & Sparkling	Dry Chill®	286mm	570W	601513	Triple Head W215xD240xH470mm

Distinctive
by design.

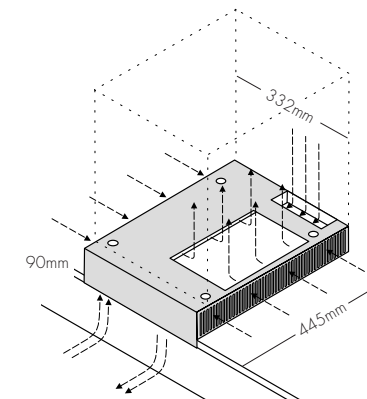

Simple-fit Ventilation Base
A refined and simple-to-install ventilation kit is included with the S2 system.



Distinctive
by design.

Additions for U2



Biodegradable paper cups
Environmentally-friendly disposable cups designed to fit Borg & Overström cup dispensers perfectly.



Personal drinking bottles
500ml capacity in black or grey frosted soft-touch finish. Comes with quick-release leak-proof cap and carry strap.



750ml glass bottles
Suitable for dishwashers and bottlewashers. Perfect fit for the U2 tap. Stylish swing-top lid.



Deep Sparkle® CO² refills
Can be disposed via standard steel recycling or general waste. Requires CO² regulator with gauge.



Sanitisation kit
Six monthly sanitising cycles ensure appliances function at the optimum hygiene levels.

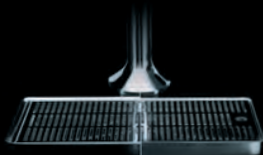

Optional drip trays
There is a range of integrated or freestanding stainless steel drip trays.



Waste kit overflow sensor
Featuring an audible high-water level alarm to prevent the waste tank from overflowing.



Install kit with 3M filter
Install appliances simply and effectively in a wide range of applications. Complete with a 3M filter.



Ultra-violet filter kit
Complete Viwandt™ filter kit to assist in water purification and removal of unwanted micro-organisms.



Mains waste kit
Mains waste kit connects the drip tray to the waste.